

836G

Landfill Compactor



Cat® 3456 EUI Diesel Engine

Gross Power 392 kW/525 hp

Flywheel Power 359 kW/481 hp

Operating Weight 53 682 kg

836G Landfill Compactor

An innovative, 21st Century landfill compactor designed for maximum production in the toughest environments.

Waste Protection

Waste resistant designs and features on the 836G combine to reduce production-robbing buildup of refuse, and provide added cooling capacity by preventing debris from entering the engine compartment.

pg. 4-5

Wheels and Tips

Cat wheels are designed for the high performance expectations of the 836G, the Cat Axle Guard System, and power train. Equipped with Plus Tips or chopper blades, the 836G will provide productive and efficient compaction, as well as excellent traction and sidehill stability on sloped material.

pg. 6

Landfill Features

✓ The Cat® Axle Guard System is available as an option along with several blades to match your site requirements – from spreading layers of refuse to dozing and clearing a dumping area.

pg. 7

Revolutionary design, Caterpillar quality.

Cat has combined decades of waste handling experience with direct customer feedback in its design of a new Landfill Compactor.

The 836 G-Series takes advantage of the latest technologies, while continuing Caterpillar's commitment to the industry since 1972.



Power Train

- ✓ *The turbocharged and aftercooled Caterpillar® 3456 Electronic Unit Injection (EUI) Diesel Engine, Caterpillar planetary power shift transmission, and Impeller Clutch Torque Converter with lockup clutch, provide improved rimpull control for precise and efficient operation.*
- pg. 8-9**

Operator Controls and Station

- Experience a high level of efficiency and comfort with a state-of-the-art cab
- ✓ *and Assist Steering, which integrates speed and direction switches into the steering wheel. One-hand operation, provided by the STIC controller, is*
 - ✓ *available as an option. More glass area provides an improved range of viewing.*
- Increased comfort through reduced sound levels, improved ventilation,
- ✓ *increased roominess, and finger tip implement controls translates to increased operator productivity.*
- pg. 11-13**

Hydraulics

- ✓ *Innovative electro-hydraulics and load sensing steering play a key role in 836G performance and provide low operator effort. Increased flow rate results in faster hydraulics. Rugged XT-3 and XT-5 hose, O-ring face seals, and large-bore cylinders carry on the tradition of reliable, high-performance Caterpillar hydraulics.*
- pg. 10**

Customer Support/Serviceability

Many convenient service features, as well as parts availability supported by a worldwide dealer network, help to reduce downtime and increase production. This illustrates Caterpillar's total commitment to customer support.

pg. 14-15

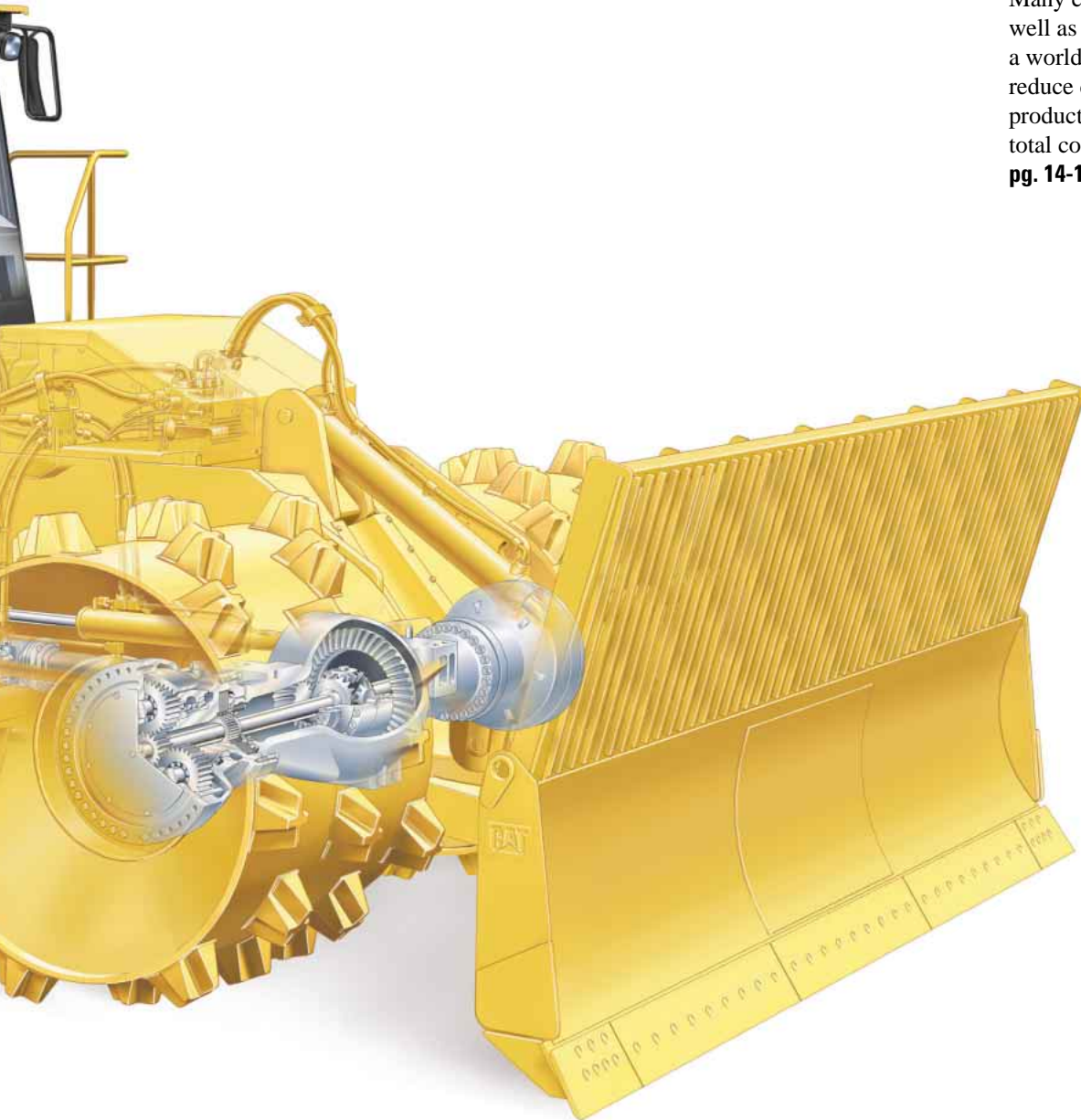

✓ *New features*

Waste Protection

Increases cooling capacity and reduces trash and debris build-up.

The new separated fan and cooling system on the 836G incorporates many trash resistant features, including an automatic reversing hydraulic demand fan, which reduces the chance of trash and debris entering the engine compartment. The system also reduces operating costs (fender cleanouts) and increases cooling capacity.

1 Roof mounted A/C makes the rear cooling package easier to clean by removing the A/C core from the rear. The frequency of cleaning the condenser core is reduced, providing better cooling to the cab for longer periods of time.

2 Air inlet screen is vertically corrugated fine mesh to help reduce trash from entering radiator area and allows debris to fall off.

3 Hydraulically driven demand fan automatically adjusts fan speed for optimum cooling, resulting in reduced power draw on the engine, better fuel efficiency, and more power for the hydraulics and rimpull.

- Demand fan swings out 65 degrees for easy cleaning.
- Reverses automatically at preset interval to remove trash from air inlet screen that may have accumulated.
- Also reverses manually from the cab.

4 AMOCS radiator module provides superior heat transfer and increased cooling with a two-pass system.

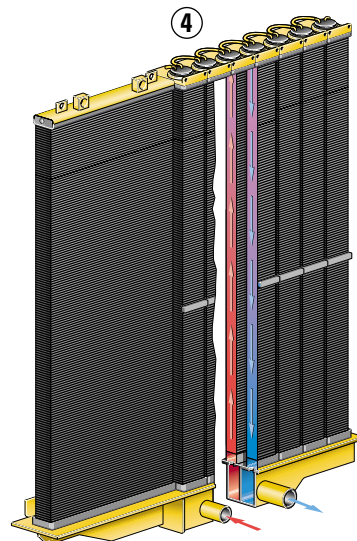



5 Electrically actuated engine and power train guards help prevent trash build-up and shield components from demolition debris, trash, wire, rebar and harmful chemicals.



6 Cab bottom guard protects hoses and wires beneath the cab from damage due to flying debris and waste.



7 Rear access walkover stairway provides easy access to operator's station. Optional swingout stairway, (see photo) provides for unparalleled access for clean-out, service and maintenance.



8 Striker bars are in front and behind the rear wheels, and behind the front wheels. They provide substantially improved protection from trash that can be thrown or carried by the wheels. The front also provides for access to the fuel tank in front frame.

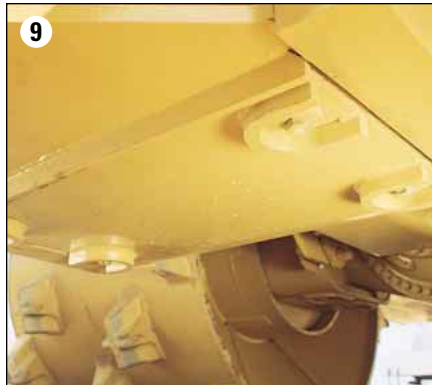

9 Bolt protection is provided on machine bottom to prevent trash from causing premature wear out.



10 Hydraulic tank is guarded to resist damage. Oil sight gauge is visible for easy checking.

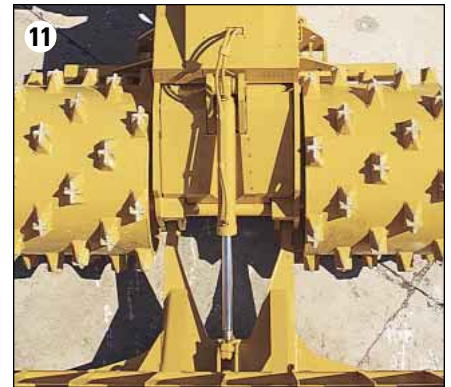

11 Front frame guards prevent trash build-up inside the frame that could damage hydraulic lines. The lift lines are in a higher location where damage from debris is less likely.

12 Fuel fill tube, optional fast fuel fill attachment, and fuel tank are positioned away from debris and easily reached.

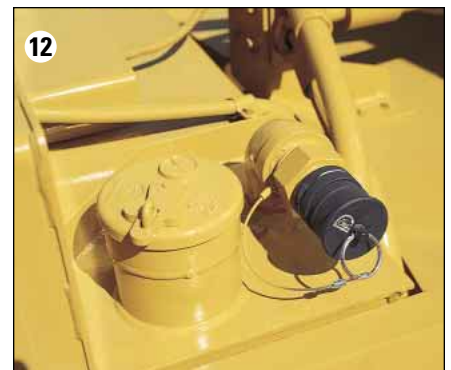

Wheels and Tips

Cat 836G Landfill Compactor offers excellent traction, productivity, and high compaction.

Extending the life of your current site through increased compaction can be a cost-effective alternative to new site development.

The Caterpillar 836G Landfill Compactor, the heaviest in its class, is available in a combination of wheel tip designs to provide productive and efficient compaction in landfill applications.

1 Long-life Weld-on Plus Tips with Extended Abrasion-Resistant Material (ARM). Exclusive Plus-shaped design provides superior compaction densities, excellent traction and sidehill stability on sloped material. A widely-spaced tip pattern, engineered to require fewer tips than competitors, results in less plugging, lower replacement cost and maximum compaction. Each tip contains more wear material than competitive tips.

- Proven exceptional compaction.
- Caterpillar guarantees 10,000 hours or four years wear life.
- Lower replacement cost.
- Cat tips offer the lowest cost per hour of any compactor tips in the industry.

2 Self-cleaning Chopper Wheels (optional) are designed to deliver maximum compaction and traction in landfill work.

- Aggressive chopping action is provided by 28 blades per wheel.
- Heat-treated DH-2, Abrasion-Resistant Material steel blades provide longer wear.
- The staggered-chevron blade arrangement evenly distributes chopping coverage and blade center gussets help assure maximum refuse demolition.
- Blades are mounted differently on front and rear wheels to maximize chopping and compaction in both forward and reverse.

Smooth wheels are also offered by Caterpillar for those customers who do not want to be limited to the tip arrangements offered but still want the designed wheel for this machine. (Also allows for the use of the Caterpillar Axle Guard System.)

An extended inner rim wheel group (optional) is available on all wheels for use with the Cat Axle Guard System.



Landfill Features

Standard and optional features are designed for heavy-duty work in waste management situations.

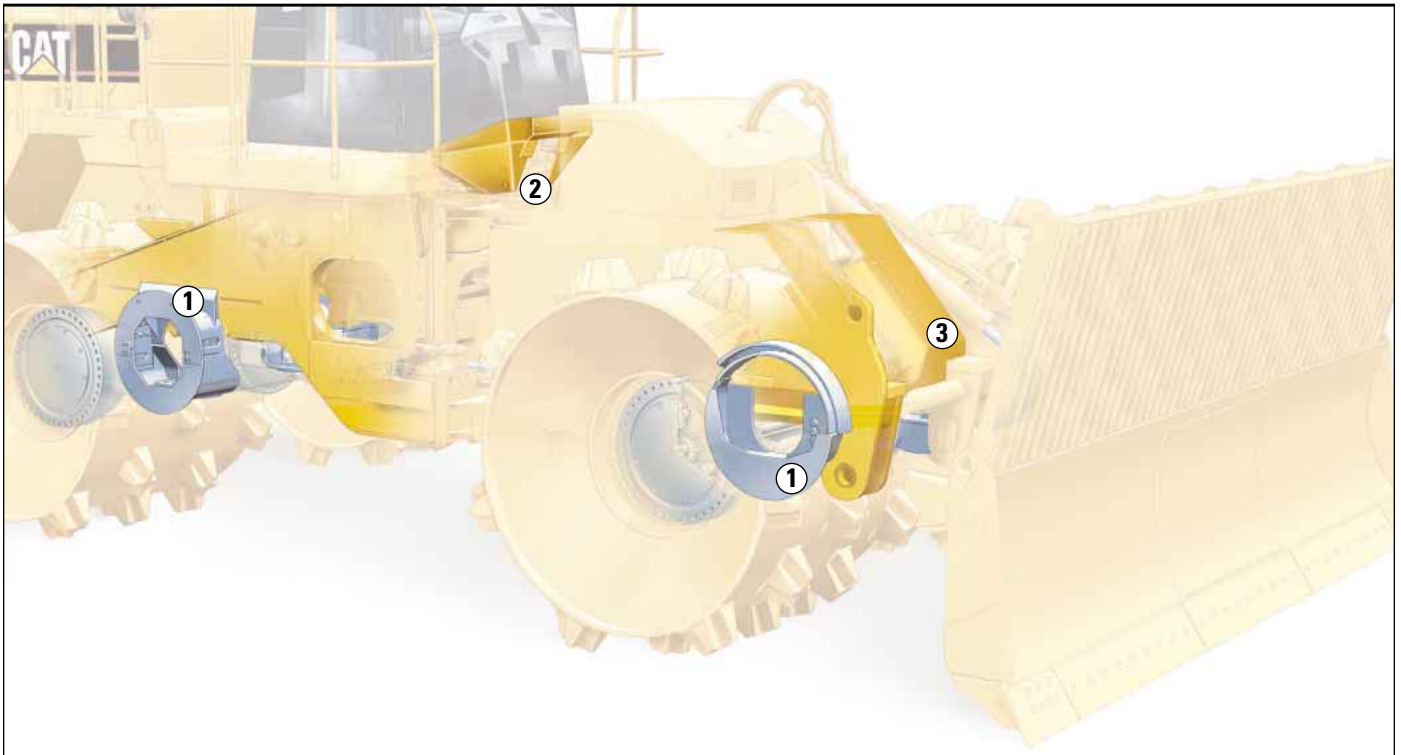

The Cat Axle Guard System (optional) protects final drives, planetaries and seals from damage caused by wire, cable, plastics or other materials which can wrap or become packed around axle components.

- Guarding increases axle circumference to avert stringy materials from wrapping and encircling the axle.
- Extended rim wheels further help to seal out materials which cling to wheel or axle surfaces.
- Recessed bolt heads reduce snagging of stringy or stranded materials.
- System reduces the need for periodic cleaning of axle assemblies.

The Axle Guard System is comprised of three basic components:

- Frame bosses are first welded to the frame.
- Bolt-on guarding assemblies (1) are then mounted onto the frame bosses and frame.
- Rim extensions complete the assembly and are welded directly to rims of the wheels.

A cab bottom guard (2) protects hoses and wires beneath the cab from damage due to flying debris and waste.

Front frame guards (3) prevent trash build-up inside the frame that could damage hydraulic lines.

Ground clearance has been increased by 76 mm.

The straight blade is ideal for most waste management applications.

- Built to withstand the rigors of heavy-duty dozing.
- Versatile blade for most applications.
- Trash rack design provides excellent viewing and load-carrying capability.
- Design incorporates Cat cutting edges.

The U-Blade is heavier and has a larger capacity than the straight blade.

- Offers more control of trash when pushing longer distances.

See a Caterpillar dealer for blade and other specialty attachments available from Caterpillar.

Power Train

836G power train components deliver dependable, reliable performance customers expect from Cat Wheel Dozers.

1 The Caterpillar 3456 Diesel Engine

is based on one of the most popular Cat engines available – the 3406E. The 3456 features 481 net horsepower, compared to the 473 horsepower available in the previous model. The 3456 provides quick response, high productivity and exceptional service life while improving fuel efficiency up to 17 percent.

- **The 49 percent torque rise** provides high lugging force during dozing and spreading applications and acceleration in high rimpull conditions.
 - The torque curve effectively matches the transmission shift points to provide maximum efficiency and faster cycle times.
- **Two-piece articulated pistons**, with forge steel crown and cast aluminum skirts, are gallery cooled by oil spray for improved oil control and increased service life. These gallery cooled steel pistons feature:
 - Better ring cooling.
 - Reduced emissions.
 - Better performance.
 - Improved fuel efficiency.
- **Airflow matched turbocharger** with power rating helps reduce emissions.
- **Nineteen percent more bearing area** allows the engine to operate at the maximum cylinder pressure.
- **Higher cylinder pressure capability** helps reduce fuel consumption and improves high altitude operation.
- **Aftercooler lowers inlet charge temperature** and reduces thermal stress that can cause premature wear of pistons, rings, and liners.
- **Cylinder head exhaust port sleeves** reduce heat rejection, which results in less heat transfer into the water jacket system.

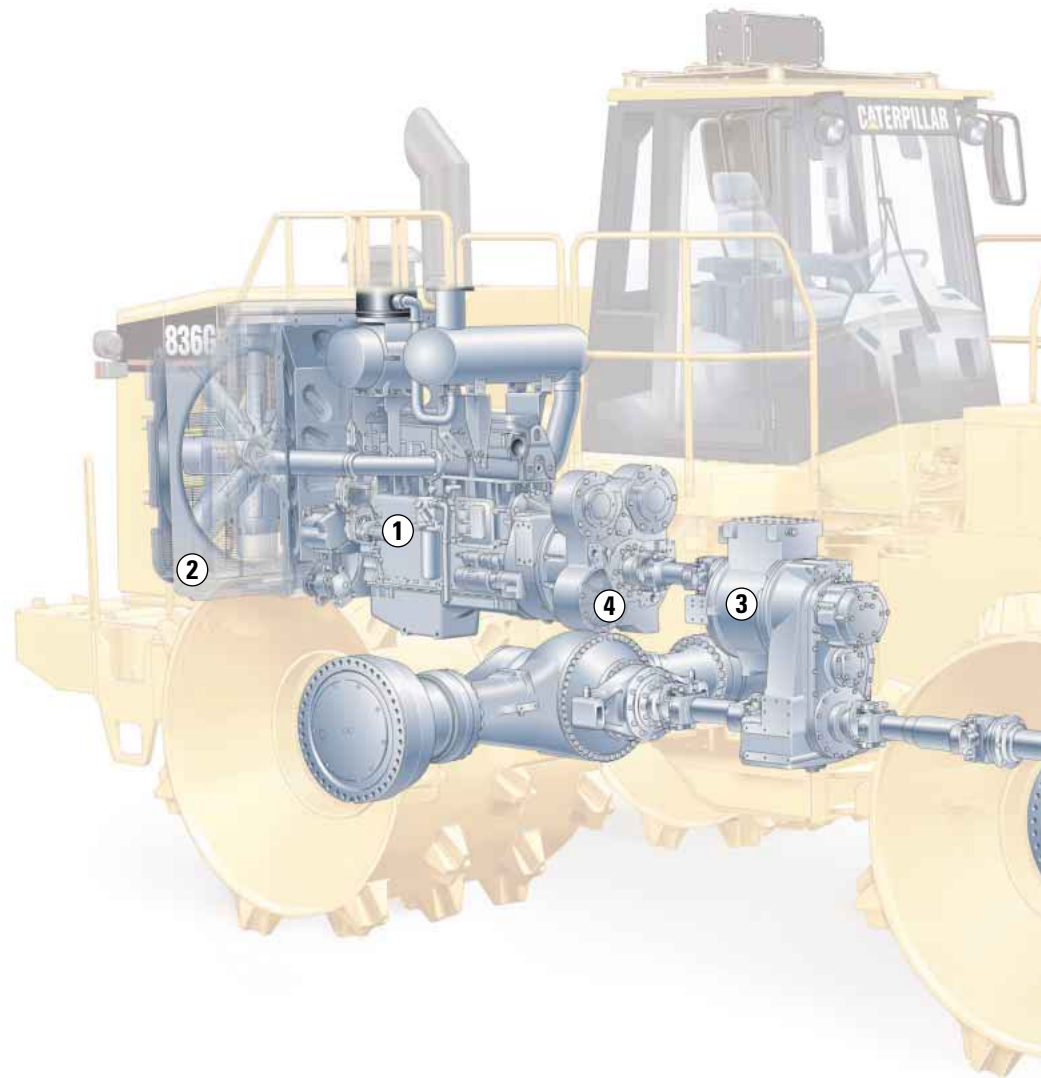

- **Advanced Diesel Engine Management II (ADEM II)** system controls the fuel injector solenoids to start and stop fuel injection. This system provides automatic altitude compensation, air filter restriction indication, and will not allow the engine to fire until it has oil pressure – acting as cold start protection.

2 Separate engine cooling system

- isolates the radiator and fan from the engine compartment, which provides:
- Lower sound levels.
 - A cleaner engine compartment.
 - A sloped hood for improved viewing.
 - More efficient cooling by drawing air through the side instead of through the engine compartment.

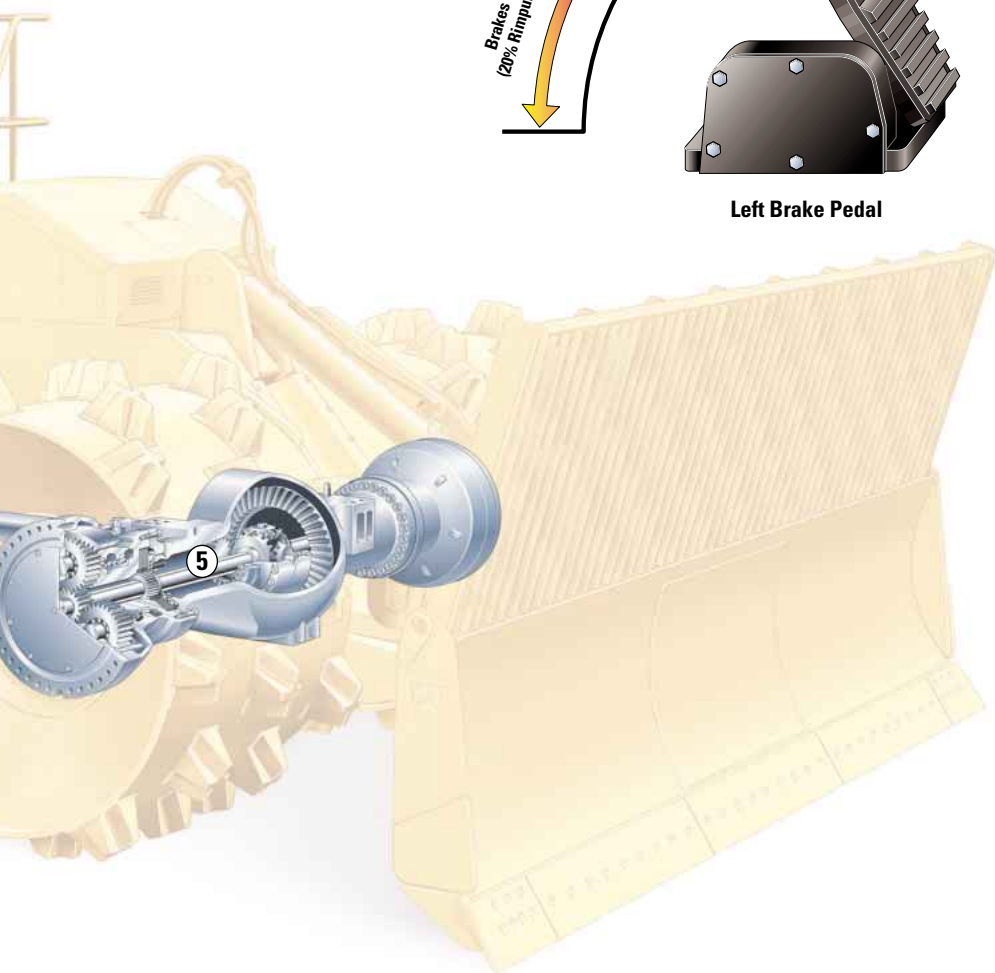

④ Maximum Rimpull Selected

20% Rimpull Selected

Brakes (20% Rimpull)

Left Brake Pedal

- **Advanced Modular Cooling System (AMOCS)** improves cooling capabilities with 10 cores using a two-pass system.
 - Coolant travels from the engine up the fan side of the cores over the top and down the engine side of the cores.
 - With no top tank to remove and no tilting of radiator guard required to remove any cores, serviceability is improved.

- ③ **Caterpillar planetary, electronic, power shift transmission.** Electronic shifting provides smooth, consistent shifts with finger tip controls housed in the steering system. Large diameter clutches coupled with four and five planet gear trains provide added durability for extended, trouble-free life.
 - **The programmable Controlled Throttle Shift** works with the transmission ECM to prolong transmission life through efficient shifting.

- ④ **Impeller Clutch Torque Converter** offers improved rimpull control and extended tip and wheel life. The torque converter is equipped with a lockup clutch and free wheel stator for improved fuel efficiency.
 - **Left pedal control** allows the operator to reduce rimpull from 100 percent to 20 percent while maintaining high engine speed for slower controlled work without a loss of power. After 20 percent is achieved, further pedal travel applies the brake.
 - **Impeller clutch.** Locked in fully engaged position for maximum engine power transfer.
 - **Lockup clutch.** Provides direct drive efficiency for increased productivity and improved fuel economy on long distance dozing.
- ⑤ **Oil-enclosed, multiple-disc brakes** on front axle provide consistent performance and reliability through heat rejection and easy serviceability.
 - **Inboard mounted brakes** operate on the low-torque side of the final drive, requiring less braking force. The location of the brake disc improves axle oil circulation, promoting efficient cooling and heat dissipation. The overall result is less heat build up and a long service life.
 - **Parking brake** is dry disc, spring applied, and oil released. It is mounted on the transmission transfer gear output shaft for manual operation.
 - **EMS II** monitors the parking brake and alerts the operator if the brake is engaged.

Hydraulics

Well-balanced hydraulics deliver precise low-effort control and trouble-free operation.



Revolutionary electro-hydraulic control system provides low-effort fingertip control. Floor-mounted control pod lever sends electrical signals to a pilot valve mounted on the front frame. This moves the sound, heat and effort caused by a hydraulic valve out of the operator's station.

1 Lift lines are in a higher location where damage from debris is less likely.

Low-effort, Assist, or STIC steering are other results of innovative design. A new mechanical feedback system and a redesigned valve ratio provide quarter-turn wheel or side-to-side STIC steering. Unlike systems that rely on steering wheel velocity to activate steering cylinders, this system directly links steering wheel or STIC position to articulation angle. This provides:

- Precise control.
- Quicker response.
- Dramatically reduced operator motion and effort.

Load sensing steering maximizes machine performance by directing power to the steering system only when the operator steers the machine. This allows more power to be applied to the ground when the machine is not being steered. It also helps decrease fuel consumption because the steering system does not constantly draw on the engine.

Caterpillar's XT-3 and XT-5 hose, O-ring face seals, and large capacity lift cylinder top off the hydraulic system, delivering the performance and durability owners expect. Reliable components reduce the risk of leaks and blown lines, helping protect the environment, and reducing operating costs.



The Reversing Demand Fan is a speed controlled, hydraulic fan that provides maximum cooling efficiency. Power is directed through the fan system only when it is needed and reverses automatically to purge debris. (Pressing rocker switch in cab may also manually reverse fan.)

Operator Controls

A revolutionary way to operate with easy-to-use, low-effort controls.



The 836G benefits significantly from the dramatic reduction in operator motion effort provided by Assist steering, STIC steering, and hydraulic blade controls. These features make the 836G the easiest operating machine in its size class.

1 Assist steering allows one hand operation of steering and transmission controls. Unlike traditional steering, which rotates more than one full turn, the assist steering wheel rotates approximately 50 degrees in both directions. Tilt and telescoping steering column help fit the machine to the operator.

2 STIC Control System (optional)

is a revolutionary system that integrates steering and transmission into a single controller. Simple side-to-side motions of the operator's left arm turn the machine right or left.

- Transmission shifting forward, neutral or reverse is controlled by the operator's fingers, and gear selection is controlled by the operator's thumb.
- Produce a fluid motion that reduces effort and allows the operator to work the machine for long periods with little or no fatigue.

3 Floor-mounted electro-hydraulic blade controls

are adjustable fore and aft, with a height-adjustable armrest so that operators of any size can find a comfortable operating position. Single lever control allows operator to control blade functions.

Operator Station

Comfort and control – a top-quality operator station will help maximize productivity.





The 836G cab design promotes productivity and operator comfort.

The cab includes improved viewing area and ventilation, intermittent wet-arm wipers, ergonomic design and control placement, and is radio-ready for two-way radios.

Improved viewing in all directions:

- Extended windows open the operator's view for exceptional forward and peripheral viewing.
- Bonded glass in the front window eliminates distracting metal frames for improved operator viewing to the blade.
- The downsloped hood improves rearward viewing by allowing the operator to see objects closer to the machine.

1 Internal ROPS improves visibility and styling, giving the 836G a sleek new look.

2 Left foot pedal operates Impeller Clutch Torque Converter for about the first inch of travel, then engages the brakes. Within the first inch of pedal travel, rimpull can be controlled from 100 percent to 20 percent.

3 Comfort Series seat is six-way adjustable and has a one inch thicker seat cushion, providing increased operator comfort and support. The seat cushions reduce the pressure on the lower back and thighs, while offering freer arm and leg movement. Air suspension adds to the overall comfort level for a smooth ride over rough terrain.

4 Throttle lock allows operator to preset the engine speed and remove his foot from accelerator pedal while maintaining constant power. The throttle lock can be deactivated by pressing the brake pedal.

5 Electronic Monitoring System (EMS) provides gauges, tachometer, speedometer, and three-level warning for full-time monitoring of key functions. The system alerts the operator of immediate or impending problems with engine oil pressure, brake oil pressure, charging system, parking brake, hydraulic oil level, transmission filter, and low fuel.

6 Heating, air conditioning and lights are controlled by easy to access rocker and rotary switches located above right door.

7 Armrests and controls are mounted on the floor and off of seat for a more durable seat and added stability of controls.

Improved ventilation ducts and vents provide better airflow to the operator and windows through 12 louvered vents, including two on each door post.

Complete Customer Support

Cat dealer services help you operate longer with lower costs.



Cat dealers offer a wide range of services that can be set up under a customer support agreement when you purchase your equipment. To help you get the best return on your investment, the dealer will help you choose a plan that can cover everything from machine and attachment selection to replacement.

Selection. Customers should make detailed comparisons of the machines under consideration before buying. Cat dealers can give precise answers to these questions: How long do components last? What is the cost of preventive maintenance? What is the true cost of lost production?

Purchase. Look past initial price. Consider the financing options available as well as day-to-day operating costs. This is also the time to look at dealer services that can be included in the cost of the machine to yield lower equipment owning and operating costs over the long run.

Operation. Improving operating techniques can boost your profits. Cat dealers have training videotapes, literature and other ideas to help you increase productivity.

Maintenance. More and more equipment buyers are planning for effective maintenance before buying equipment. Choose from a Cat dealer's wide range of maintenance services at the time of purchase. Repair option programs guarantee the cost of repairs up front. Diagnostic programs such as S•O•SSM Fluids Analysis and Technical Analysis help avoid unscheduled repairs.

Replacement. Repair, rebuild or replace? Cat dealers can help evaluate the cost involved so you can make the right choice.

Product support. You will find nearly all parts at a Cat dealer parts counter. Cat dealers utilize a world-wide computer network to find in-stock parts to minimize machine down time. Save money with remanufactured parts. You receive the same warranty and reliability as new products at cost savings of 40 percent to 70 percent.

Literature support. An easy-to-use operation and maintenance manual helps you get the full value from an equipment investment.

Serviceability

Keep your machine up and running with easy-to-perform daily maintenance.



Accessibility for daily maintenance has never been easier than on the 836G. If maintenance is simple and accessible, it gets done.

1 Standard swing-out radiator fan provides for easy access to the radiator cores for easy cleaning and/or inspection.

2 Advanced Modular Cooling System (AMOCS) maintenance is simplified since it is isolated from the engine compartment and allows service technicians to replace individual cores for enhanced serviceability.

3 Swing-out doors on both sides of the engine compartment provide easy access to the engine oil dipstick and filler spout, S•O•S port, fuel filters, engine oil filters, alternator, starting receptacle, air filter service indicator and ether starting aid. Disconnect switch and diagnostic connector are located in rear platform.

4 Cab support bracket provided with every machine improves access under the cab. The bracket is conveniently stored behind the cab.

5 Optional swing out stairways provide easy inspection of rear axle components and access to engine compartment.

Electronic Monitoring System II notifies the operator and service technician of potential problems and logs events.

Diagnostic connector enables quick evaluation of eleven starting and charging functions.

U-Joints and slip shaft are permanently lubricated.

Lube points are centralized in accessible locations from ground level for quicker and easier service.

Engine

Four-stroke cycle, six cylinder, Cat 3456 Turbocharged and Air-to-air Aftercooled Diesel Engine.

Ratings at 1900 rpm	kW	hp
Gross power	392	525
Net power	358	481

Direct Drive

Net Power	kW	hp
EEC 80/1269	336	451
ISO 9249	336	451

Converter Drive

Net Power	kW	hp
EEC 80/1269	358	481
ISO 9249	358	481

Dimensions

Bore	140 mm
Stroke	172 mm
Displacement	15.8 liters

Power rating conditions

- net power advertised is the power available at the flywheel when the engine is equipped with air cleaner, muffler, alternator, and hydraulic fan drive
- no derating required up to 2286 m altitude

Features

- direct-injection fuel system with individual adjustment-free injection pumps and valves
- three-ring, aluminum alloy pistons, cam-ground, tapered and cooled by oil spray
- steel-backed, copper-bonded, aluminum crankshaft bearings
- pressure lubricated with full-flow filtered and cooled oil
- dry-type air cleaner with primary and secondary elements, automatic dust ejector and service indicator
- direct-electric 24-volt starting system with ether, 100-amp alternator and two, 12-volt, 190-amp-hour batteries

Transmission

432 mm planetary power shift transmission with two speeds forward and reverse.

Maximum speeds, forward and reverse, with lock-up (clutch) engaged.

Forward	km/h
1	6.1
2	10.9
Reverse	km/h
1	6.4
2	11.4

Features

- electronic shift control
- control throttle shift feature
- speed and direction finger tip controls are housed in Assist steering wheel or optional STIC controller
- Impeller Clutch Torque Converter is standard with lockup clutch

Axles

Fixed front, oscillating rear ($\pm 6^\circ$).

Features

- maximum single-wheel rise and fall 448.3 mm
- bevel gear set and differentials
- Duo-Cone seal between axle hub and housing
- axle shaft brakes
- use SAE 30 or 40W (depending on temperature) (oil change interval every 2000 hours or one year)

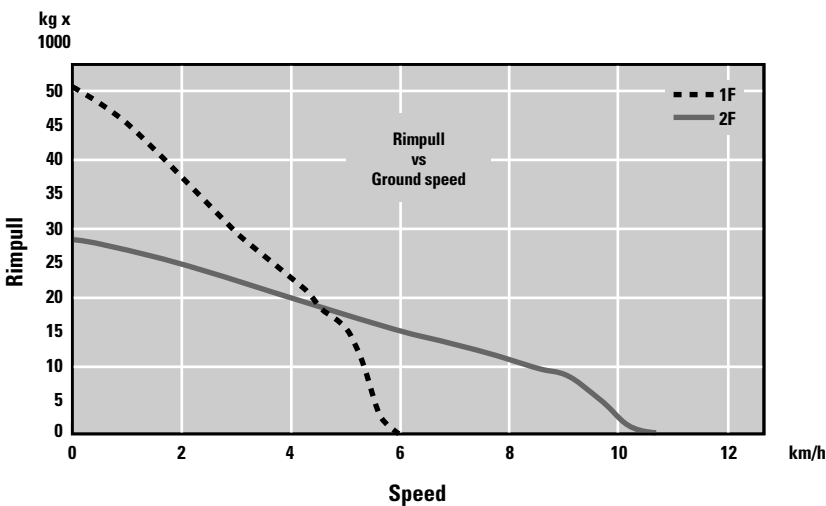

Brakes

Meets the following standard: ISO 3450-1985.

Service brake features

- brakes located on two front wheels with stopping capability provided to all four wheels through full-time all-wheel driveline
- completely enclosed
- self adjusting with modulated engagement
- two brake pedals allow standard braking with right pedal and transmission neutralization braking with left pedal
- ease of service by unbolting spindle joint to expose brake components

Parking brake features

- spring applied, oil-released, dry drum brake
- mounted on transmission output shaft driveline for manual operation
- electronic monitoring system alerts operator if transmission is engaged while parking brake is applied

Secondary brake features

- electronic monitoring system alerts operator if pressure drops and automatically applies parking brake
- operator can apply manually

Hydraulic System

Gear pump output at 2014 rpm and 2400 kPa 188 l/min

Relief valve setting 24 100 kPa

Lift cylinder bore x stroke 127 mm x 740 mm

Final Drives

All-wheel drive.

Features

- planetary reduction at each wheel
- torque developed at the wheel, less stress on the axle shafts
- planetary units can be removed independently from the wheels and brakes

Wheels

Plus Tip Teeth wheels with Abrasion-Resistance Material (ARM).

Drum width 1397 mm

Outside diameter 2050 mm

Drum diameter 1720 mm

Tips per row 7

Tips per wheel 35

Replacement weld-on

Chopper-blade wheels (optional)

Drum width 1397 mm

Outside diameter 1992 mm

Drum diameter 1672 mm

Blades per row 7

Blades per wheel 28

Frame

Articulated frames fabricated from steel plate and rolled box sections.

Features

- front and rear frames coupled by two hardened steel pins
- each pin rides in two tapered roller bearings
- robotically welded for increased fatigue strength

Cab

Caterpillar cab with integrated Rollover Protective Structure (ROPS) are standard.

Features

- reduced sound levels
- the operator sound pressure level measured according to the ISO 6396 dynamic test method is 76 dB(A)
- standard air conditioning system contains the environmentally safe R134a refrigerant
- ROPS meets the following criteria: ISO 3471: 1994
- Also meets the following criteria for Falling Objects Protective Structure: ISO 3449: 1992 Level II
- spectator sound is 115 dB(A) as measured per ISO6395

Service Refill Capacities

Fuel tank 795 Liters

Cooling system 91

Crankcase 60

Transmission 83

Differentials and final drives *

front 148

rear 148

Hydraulic system (including tank) 240

Hydraulic tank 140

* With 2 liters of additive

Blades

	Straight Blade	U-Blade
Width over end bits	5193 mm	5273 mm
Height	2222 mm	2215 mm
Lift speed at rated rpm	364 mm/sec	364 mm/sec
Cutting edges, reversible:		
Length, each end section (3 edges)	1408.2 mm	817 mm
Length, each end section (2 edges)	–	990 mm
Width x thickness	254 mm x 25 mm	254 mm x 25 mm
End bits (2), self-sharpening:		
Length, each	472 mm	Right 472 mm Left 432 mm
Width x thickness	254 mm x 25 mm	254 mm x 25 mm
Capacity, rated	19.8 m ³	25.8 m ³
Turning radius outside corner of blade	8737 mm	9125 mm

Note: See your Cat dealer for other blade options.

Weight

(approximate)

Maximum operating weight includes ROPS cab, full fuel tank, coolant, lubricant, landfill blade, 1397 mm Plus Tips, an 82 kg operator and all available options with the greatest weight 53 682 kg.

Note: Optional equipment weight varies.

Dimensions

All dimensions are approximate.

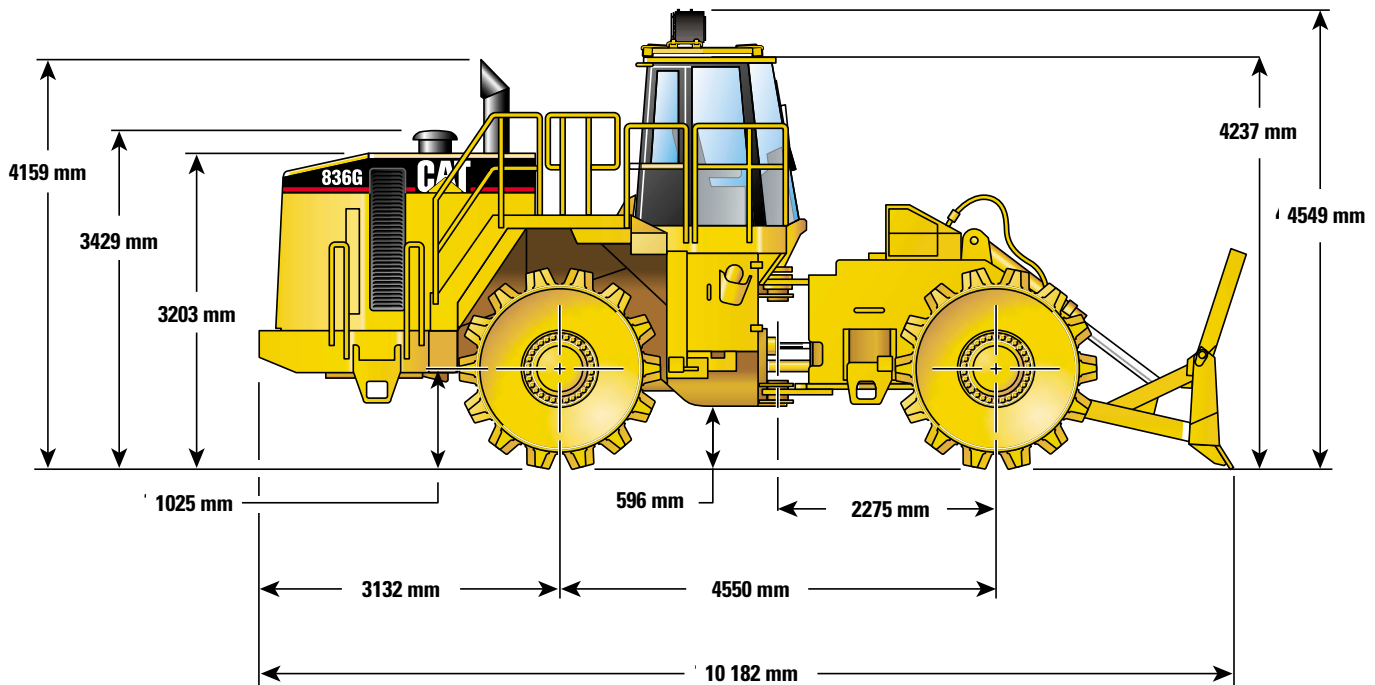

Width

Over end bits	5193 mm
Over drums	4280 mm
Between drums	1480 mm

Standard Equipment

Standard and optional equipment may vary. Consult a Caterpillar dealer for specifics.

Electrical

100-amp alternator
Backup alarm
Electric starter (heavy-duty)
Lighting system, Halogen
(front and rear)
Maintenance-free batteries
Master disconnect, lockable
Starting receptacle for emergency
starting
Starting and charging system
diagnostic connector

Operator environment

Air conditioner (roof mounted)
Air suspension Cat Comfort seat
Cab, ROPS, sound suppressed,
pressurized
Cigar lighter
Dome lights (cab)
Electric horn
Electro-hydraulic implement controls
Gear selection display
Heater and defroster
Hour meter display, electric
Implement system lock
Electronic Monitoring System II
(EMS II) Instrumentation
Gauges (4):
Engine Coolant Temperature
Hydraulic Oil Temperature
Torque Converter Temperature
Fuel Level

Warning Indicators (9)
Brake Oil Pressure
Coolant Flow Status
Electrical System, low voltage
Engine Oil Pressure
Hydraulic Filter Status
Parking Brake Status
Steering Oil Pressure
Transmission Filter Status
Engine Overspeed
Radio-ready cab for entertainment or
2-way radio (Antenna, Speakers, and
Converter included)
Rearview mirrors (exterior mounted)
Seat belt, retractable
Steering, Assist (wheel) pilot operated
Throttle lock
Wet-arm wiper/washers (front and rear)

Power train

Advanced Modular Cooling System
(AMOCS) radiator
Caterpillar 3456 EUI Diesel Engine
(with 500 hour oil change interval
crankcase and CH4 oil)
Differentials, NoSPIN (front)
Engine air intake precleaner
Fuel priming aid (ether)
Full hydraulic, enclosed, wet
multiple-disc brakes (front)

Hydraulically driven, automatically
reversible Demand fan (swing out)
Planetary power shift transmission with
2F/2R speed range control
Muffler (under hood)
Torque converter, Impeller Clutch with
Lockup Control System
Transmission neutralizer on/off switch

Other standard equipment

Drawbar hitch with pin
Electrically actuated power train and
crankcase guards
Engine, crankcase, 500-hour interval
with CH4 oil
Hydraulic oil cooler
Landfill guard package
Locking engine enclosures
Stairways, fixed left and right
(rear access)
Striker bars
Vandalism protection caplocks

Wheels

1397 mm, long-life, weld-on plus tips
with 7 wear bars on inside wheel disc

Optional Equipment

With approximate changes in operating weights.

	kg		kg
Axle guards		Heater, engine coolant	1.8
Front	374	Mirror, inside (panoramic)	5
Rear	690	Sound suppression	80
Bulldozer arrangement		Stairway, Swing, left and right	54
Straight blade	3120	STIC Steering	-4
U-blade	3840	Wiper, Intermittent rear	1
Cab, Rubber mounted glass	14	Visor, Front	5
Cleaner bars, front and rear (fingers between Plus Tips)	1111	Wheels	
Differentials, NoSPIN (rear)	5	Smooth	-3827
Fast fill system		Chopper blades	-1810
Fuel	4	Rim Extensions (for axle guards)	1060
Oil	1.2	Various wheels, see price list	
Filtration, Case Drain	12		

836G Landfill Compactor

HEHG5343 (11/2000) hr

Materials and specifications are subject to change without notice.
Featured machines in photos may include additional equipment.
See your Caterpillar dealer for available options.

www.CAT.com
© 2000 Caterpillar

CATERPILLAR[®]